

TO-126 Plastic-Encapsulate Transistors

13003 TRANSISTOR (NPN)

FEATURES

Power switching applications

MAXIMUM RATINGS ($T_a=25^\circ\text{C}$ unless otherwise noted)

Symbol	Parameter	Value	Unit
V_{CBO}	Collector-Base Voltage	700	V
V_{CEO}	Collector-Emitter Voltage	400	V
V_{EBO}	Emitter-Base Voltage	9	V
I_C	Collector Current -Continuous	1.5	A
P_C	Collector Power Dissipation	1.25	W
$R_{\theta JA}$	Thermal Resistance from Junction to Ambient	100	$^\circ\text{C}/\text{W}$
T_j	Junction Temperature	150	$^\circ\text{C}$
T_{stg}	Storage Temperature	-55~+150	$^\circ\text{C}$

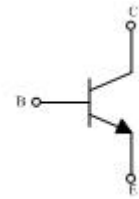
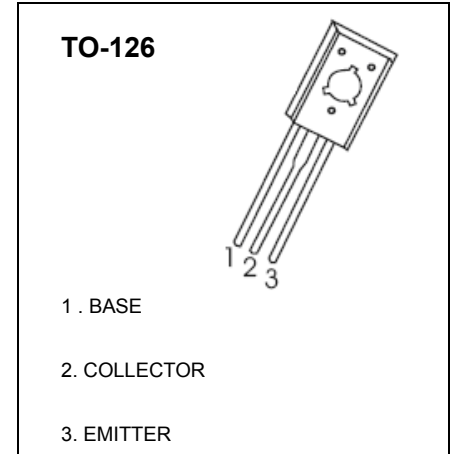

ELECTRICAL CHARACTERISTICS ($T_a=25^\circ\text{C}$ unless otherwise specified)

Parameter	Symbol	Test conditions	Min	Typ	Max	Unit
Collector-base breakdown voltage	$V_{(BR)CBO}$	$I_C=1\text{mA}, I_E=0$	700			V
Collector-emitter breakdown voltage	$V_{(BR)CEO}$	$I_C=10\text{mA}, I_B=0$	400			V
Emitter-base breakdown voltage	$V_{(BR)EBO}$	$I_E=1\text{mA}, I_C=0$	9			V
Collector cut-off current	I_{CBO}	$V_{CB}=600\text{V}, I_E=0$			10	μA
Collector cut-off current	I_{CEO}	$V_{CE}=400\text{V}, I_B=0$			10	μA
Emitter cut-off current	I_{EBO}	$V_{EB}=9\text{V}, I_C=0$			10	μA
DC current gain	$h_{FE(1)}$	$V_{CE}=5\text{V}, I_C=0.5\text{A}$	10		40	
	$h_{FE(2)}$	$V_{CE}=5\text{V}, I_C=1\text{mA}$	10			
	$h_{FE(3)}$	$V_{CE}=5\text{V}, I_C=1\text{A}$	10			
Collector-emitter saturation voltage	$V_{CE(sat)1}$	$I_C=0.5\text{A}, I_B=0.1\text{A}$			0.35	V
	$V_{CE(sat)2}$	$I_C=1\text{A}, I_B=0.2\text{A}$			0.65	V
Base-emitter saturation voltage	$V_{BE(sat)1}$	$I_C=0.5\text{A}, I_B=0.1\text{A}$			1	V
	$V_{BE(sat)2}$	$I_C=1\text{A}, I_B=0.2\text{A}$			1.2	V
Storage time	t_s	$I_C=250\text{mA}$	2		4	μs

CLASSIFICATION of $h_{FE(1)}$

Range	10-15	15-20	20-25	25-30	30-35	35-40
-------	-------	-------	-------	-------	-------	-------

CLASSIFICATION of t_s

Rank	A1	A2	B1	B2
Range	2-2.5	2.5-3	3-3.5	3.5-4

Typical Characteristics

